

# BI5 Series

## DDR Torque Motor

The BI5 series is a frameless DDR torque motor launched by Han's Motor, featuring high performance, low inertia, fast response, and strong overload capacity, capable of meeting the vast majority of market demands.

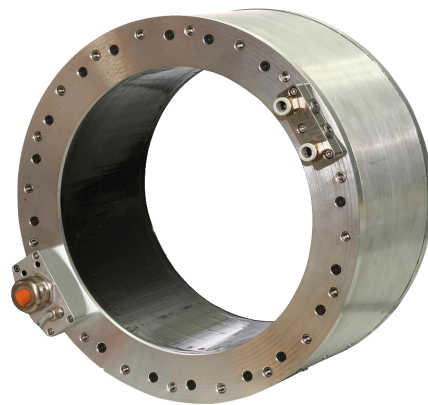

### Features

- Renishaw absolute encoder
- High speed or low speed winding design
- Reliable performance, mature process, fast delivery
- It can be divided into stator and rotor, the maximum peak torque is 5500Nm

### Applications

- 3C Devices
- Display Panels
- Semiconductors
- Medical Equipment
- Precision Machine Tools
- PCB Equipment and Other Applications

## Parameters

**HAN'S MOTOR**

<b>BI5-xxx-P-x-0-W</b>	<b>Symbol</b>	<b>Unit</b>	<b>050-P-A-0</b>	<b>080-P-B-0</b>
Pole Pairs	p	—	33	33
Max.Working Bus Voltage	Vdc	V	540	600
Peak Torque	Tp	Nm	1000.0	1453.2
Continuous Torque (Water Cooling)	Tcw	Nm	546.0	844.2
Continuous Torque (Natural Cooling)	Tc	Nm	234.0	365.4
Peak Current	Ip	Arms	50	173
Continuous Current (Water Cooling)	Icw	Arms	21	67
Continuous Current (Natural Cooling)	Ic	Arms	9	29
Torque Constant	Kt	Nm / Arms	26.0	12.6
Back EMF Constant	Ke	Vrms / rad / s	8.7	4.2
Back EMF Constant	Ke	Vrms / (1000 r / min)	1572.0	761.8
Line Resistance	R	$\Omega$	3.2	0.5
Line Inductance	L	mH	14.0	1.2
Max.Speed, Tcw	Nmax, Tcw	rpm	130	450
Max.Speed, Tc	Nmax, Tc	rpm	190	500
Max.Speed, Tp	Nmax, Tp	rpm	10	330
Max.Speed, 0	Nmax	rpm	230	535
Power Consumption, Output Tcw	Plw	W	5557.0	4242.1
Power Consumption, Output Tc	Plc	W	1021.0	794.7
Motor Constant	Km	Nm / $\sqrt{W}$	10.0	13.0
Cooling Water Flow	dV / dt	L / min	6.8	7.5
Cooling Water Temperature Difference Setting	$\Delta\theta$	k	5	5
Rated Winding Temperature	$\theta$	$^{\circ}C$	130	130
Motor Mass	Ms	Kg	25.5	34.0
Rotor Mass	Mr	Kg	7.5	10.5
Rotor Moment of Inertia	Jm	Kg * m <sup>2</sup>	0.1420	0.2020
Cable Length (Can Be Extended Optional)	L	M	3.0	3.0
Cable Minimum Bending Radius	R	mm	102.0	102.0

\* All specifications are typical data and subject to change without notice due to product improvements.

**HAN'S COMPONENTS**  
www.hl-components.com

## Parameters

**HAN'S MOTOR**

<b>BI5-xxx-P-x-0-W</b>	<b>Symbol</b>	<b>Unit</b>	<b>120-P-B-0</b>	<b>140-P-A-0</b>
Pole Pairs	p	—	33	33
Max.Working Bus Voltage	Vdc	V	600	600
Peak Torque	Tp	Nm	2156.8	2440.0
Continuous Torque (Water Cooling)	Tcw	Nm	1226.1	1365.0
Continuous Torque (Natural Cooling)	Tc	Nm	549.0	585.0
Peak Current	Ip	Arms	165	48.8
Continuous Current (Water Cooling)	Icw	Arms	67	21
Continuous Current (Natural Cooling)	Ic	Arms	30	9
Torque Constant	Kt	Nm / Arms	18.3	65.0
Back EMF Constant	Ke	Vrms / rad / s	6.1	21.7
Back EMF Constant	Ke	Vrms / (1000 r / min)	1106.4	3930.0
Line Resistance	R	$\Omega$	0.6	6.8
Line Inductance	L	mH	2.6	38.0
Max.Speed, Tcw	Nmax, Tcw	rpm	300	56
Max.Speed, Tc	Nmax, Tc	rpm	340	85
Max.Speed, Tp	Nmax, Tp	rpm	180	35
Max.Speed, 0	Nmax	rpm	370	105
Power Consumption, Output Tcw	Plw	W	5656.1	6483.0
Power Consumption, Output Tc	Plc	W	1134.0	1191.0
Motor Constant	Km	Nm / $\sqrt{W}$	16.3	17.0
Cooling Water Flow	dV / dt	L / min	9.5	10.0
Cooling Water Temperature Difference Setting	$\Delta\theta$	k	5	5
Rated Winding Temperature	$\theta$	$^{\circ}C$	130	130
Motor Mass	Ms	Kg	47.0	60.0
Rotor Mass	Mr	Kg	15.5	17.8
Rotor Moment of Inertia	Jm	Kg * m <sup>2</sup>	0.3020	0.3505
Cable Length (Can Be Extended Optional)	L	M	3.0	6.0
Cable Minimum Bending Radius	R	mm	102.0	102.0

\* All specifications are typical data and subject to change without notice due to product improvements.

**HAN'S COMPONENTS**  
www.hl-components.com

**Laser Dimensions (mm)**

*HAN'S MOTOR*

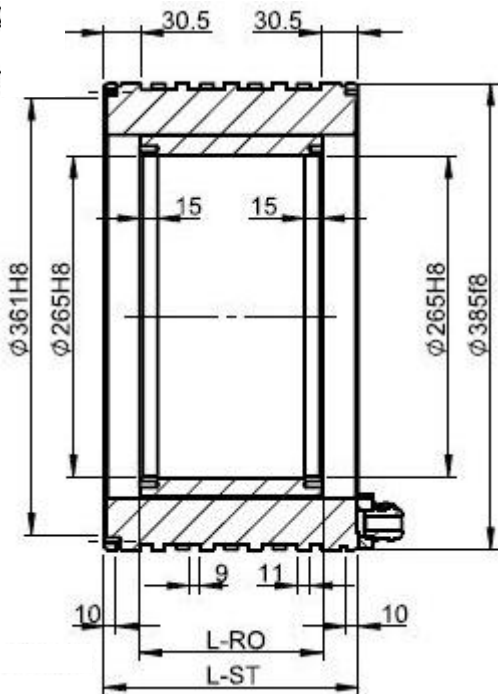
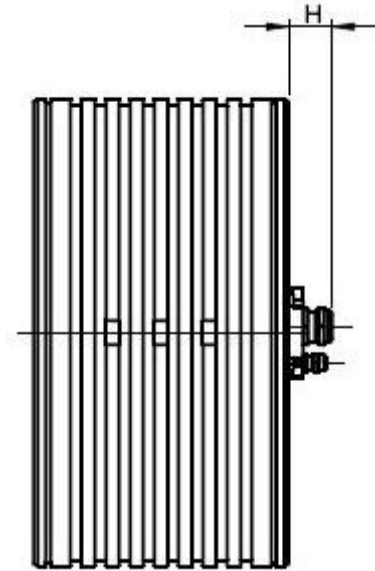
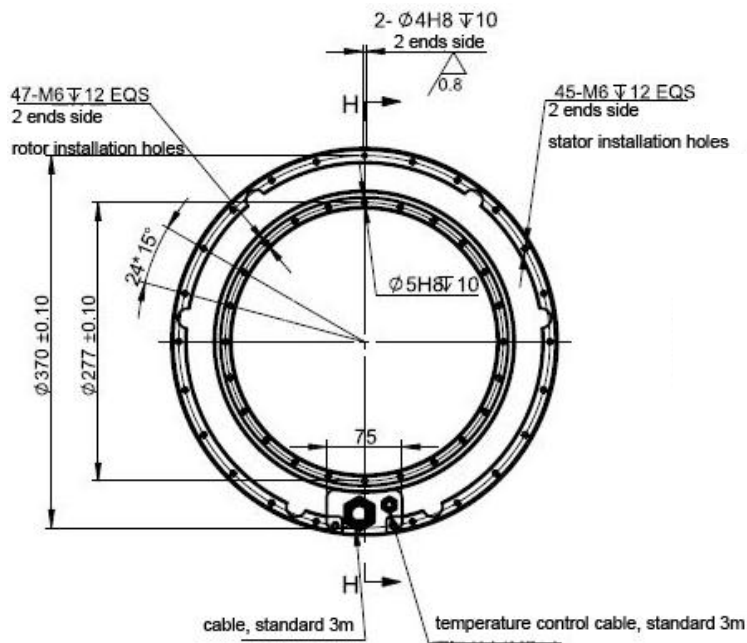

Model	Center Hole(mm)	Outer Diameter	Height/mm	Spec.	Continuous torque/Nm	Peak torque/Nm
BI5 (Water Coling)	265	385	130	BI5-050	546	1000
			160	BI5-080	844	1453
			210	BI5-120	1226	2157
			235	BI5-140	1365	2440